



Purpose and Application

Continuous monitoring of the conductivity of liquids, signalling of limit values, remote indication or recording with the GESTRA conductivity transmitter type LRT 1-5b or LRT 1-6b.

Application in steam boiler plants for feed-water and condensate monitoring, as well as in district heating plants, paper and wood-working industries, catering kitchens, for dyebath monitoring in dye works, for conductivity monitoring in water treatment plants.

Design

The conductivity electrode is provided with two electrode tips completely insulated by a PTFE tubing with the exception of the free ends. The non-insulated ends form together with a PTFE sleeve a measuring cell. The screwed body incorporates a temperature feeler. A system of compression springs ensures a pressure-tight sealing between electrode tips and body even at varying temperatures.

The conductivity electrode type LRG 12-1 is supplied with a screwed connection 1/4" BSP, PN 10 (1/4" NPT on request).

Operation

For monitoring the liquid, its conductivity is used. The conductivity produces a proportional current if measuring surface and voltage supply remain constant.

Modifications in conductivity owing to temperature changes are compensated by the temperature feeler.

Technical Data

Max. service pressure
10 barg (145 psig)

Max. service temperature
184 °C

Connection
Screwed 1/4" BSP (DIN 259)
(Screwed 1/4" NPT on request)

Materials
Body: X6CrNiMoTi 17 12 2 (DIN No. 1.4571)
Electrode tips: 1.4571
Insulating tubing: PTFE
Sleeve: PTFE
Terminal box: Plastics

Cell constant of electrode
C = 1.0 [1/cm]

Max. permissible ambient temperature
at terminal box
60 °C

Electric connection
Four-pole connector with screw terminals, cable strain relief and cable gland
Pg 11

Approx. weight
1 kg

Important Notes

Cable required for wiring: Screened cable, e.g. 6 x 0.8 mm² for wiring to the LRT 1-5b, 4 x 0.8 mm² for wiring to the LRT 1-6b, max. cable length see data sheet LRT 1-...

The conductivity electrode may be installed vertically or horizontally. The open end (measuring cell) must be constantly submerged.

For fluid temperatures above 120 °C horizontal installation is recommended to ensure that the max. permissible temperature of 60 °C at the terminal box is not exceeded.

Order and Enquiry Specifications

GESTRA conductivity electrode used as sensor for conductivity monitoring:

Conductivity electrode type LRG 12-1, PN 10, with screwed connection 1/4" BSP (1/4" NPT on request).

The following test certificates can be issued on request, at extra cost:

In accordance with DIN EN 10204-2.1, -2.2 and -3.1 B.

All inspection requirements have to be stated with the order. After supply of the equipment certification cannot be established. For tests and inspection charge please consult us.

Associated Equipment

Conductivity transmitter type LRT 1-5b or LRT 1-6b as measuring transducer with current output 0 to 20 mA or 4 to 20 mA.

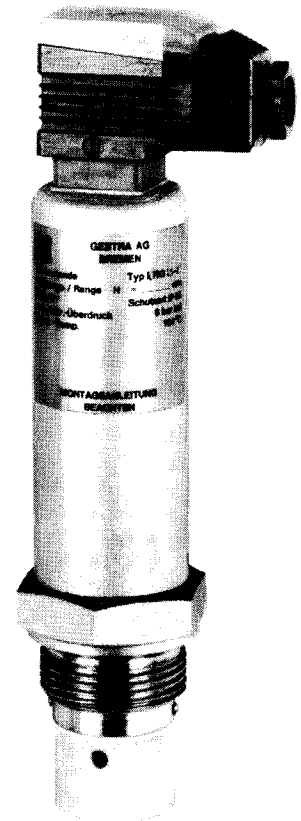

Conductivity electrode LRG 12-1

B₁

LRG 12-1



Installation and Service Instructions

Handle conductivity electrode with care.

Installation

Screw electrode with ring joint supplied and/or Teflon tape into vessel and tighten.

It is absolutely necessary that the measuring cell protrudes from the screwed socket **by at least 10 mm** (see figure opposite).

Note

The electrode body situated above the hexagonal part must not be insulated.

Wiring

Always use screened cable for wiring. Connect screen only to corresponding terminal of the electronic unit connected to the electrode in accordance with respective wiring diagram. Do not connect screen to earth terminal of electrode.

When several electrodes are fitted in a steam boiler or vessel, the electrode body and the terminal box should be marked to avoid confusion.

Maintenance

The electrode does not require any particular maintenance. It is, however, recommended to check the electrode tips from time to time as they must stay free from deposits. To clean electrode tips rinse measuring cell with trichloroethylene or similar or with 10% hydrochloric acid.

Dimensions

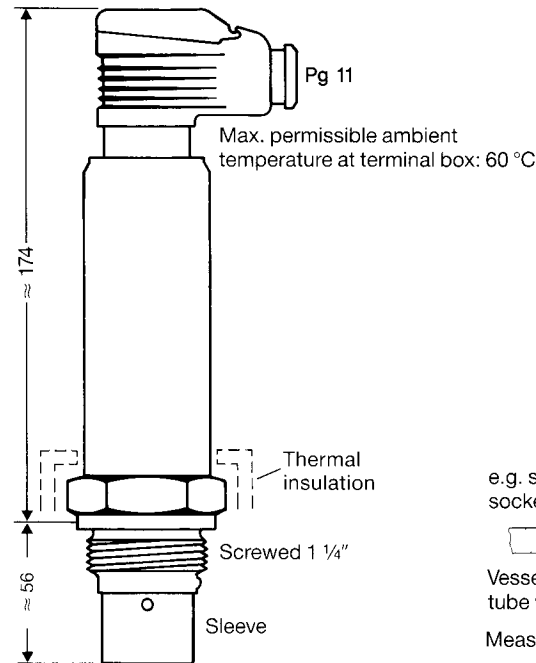

Conductivity electrode type LRG 12-1

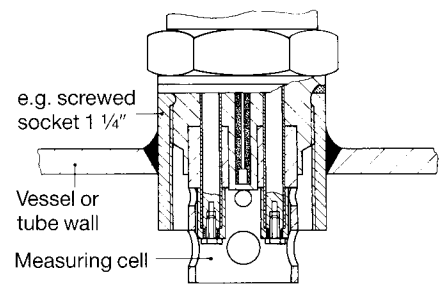

Installation of conductivity electrode into a screwed socket

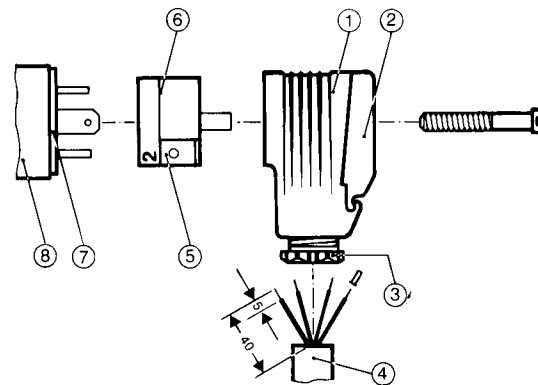

- ① Terminal box housing
- ② Cap
- ③ Cable gland Pg 11 with internal cable strain relief for circular cables 6-10 mm diameter
- ④ Connecting cable
- ⑤ Terminal block with terminals
- ⑥ Strip with terminal marking points
- ⑦ Flat joint gasket
- ⑧ Plug on electrode head

Terminal box with item numbers and marking points

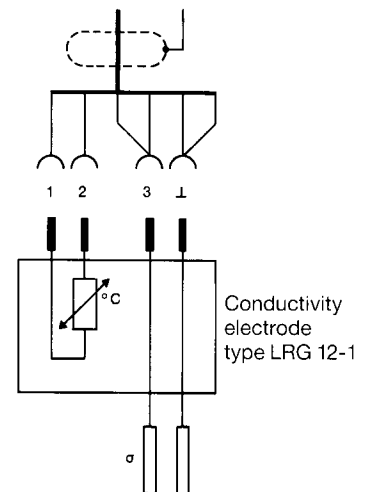

Wiring in the terminal box

Technical modifications reserved.